

**Montageanleitung
DORMA
ARCOS Band
mit Rahmenteil für
zargenunabhängige Türen**

**Installation instructions
DORMA
ARCOS hinge
with frame pivot for
non-rebated frames**

A yellow rectangular box containing the Glas Scholl logo, a coat of arms, and contact information. The logo features the text "Glas Scholl" in a stylized font with a crown above it, and "Inh. Dirk Lankemann" below. To the left is a coat of arms with the text "seit 1727". Below the logo is a telephone icon with "24 Std" inside. The contact information includes the address "Paul-Rücker-Str. 12 47059 Duisburg", phone numbers "Mülheim 0208 / 58 90 000" and "Duisburg 0203 / 99 30 60", and a telefax number "Telefax 0203 / 99 306 33". At the bottom, it says "Internet www.Glas-Scholl.de".

seit 1727
Glas Scholl
Inh. Dirk Lankemann
Paul-Rücker-Str. 12 47059 Duisburg
Mülheim 0208 / 58 90 000
Duisburg 0203 / 99 30 60
Telefax 0203 / 99 306 33
Internet www.Glas-Scholl.de

Wichtige Informationen:
Important information:

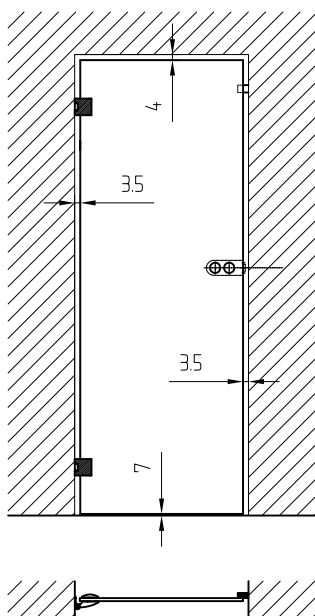

① = Bauteil/Baugruppe
 Component

1. ; 1.1 ; ... = Montagefolge
 Installation sequence

Vor der Montage Glasflächen mit handelsüblichem Glasreiniger im Bereich der Klemmflächen reinigen.

All glass clamping areas have to be cleaned with standard glass cleaning products prior to installation.



keine Verdünnung verwenden
 Do not use thinners



Es werden zwei Personen zur Montage benötigt!
 Two persons are necessary for the installation work!

Glasbearbeitung:
Glass preparation:

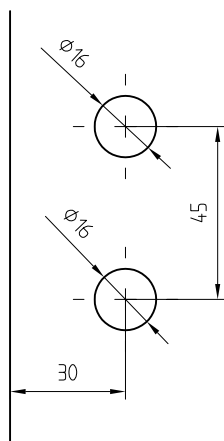

Montagewerkzeug:
Requisite tools:

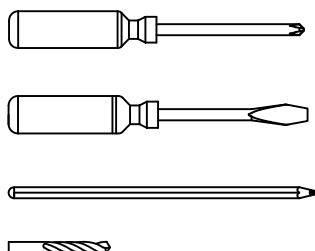

Pflege allgemein:

Die Oberflächen der Beschläge sind nicht wartungsfrei und sollten gemäß ihrer Ausführung gereinigt werden.

- Für metallische Oberflächen (Eloxaltöne, Edelstahl) bitte nur geeignete Reiniger ohne Scheuermittelanteil verwenden.
- Für lackierte Oberflächen bitte nur entsprechende lösemittelfreie Reiniger verwenden.
- Messing Oberflächen (ohne Oberflächenschutz) müssen von Zeit zu Zeit mit geeignetem Pflegemittel behandelt werden, um Anlaufen zu vermeiden.

Wartung allgemein:

Wir empfehlen die Funktion der Beschläge alle 200.000 Bewegungen, durch Fachleute, zu prüfen.

General care instructions:

The surface finishes of the fittings are not maintenance-free and should be cleaned according to their material and texture.

- For metallic surfaces (anodised finishes, stainless steel) please only use appropriate cleaning agents without abrasive additives.
- For varnished surfaces please only use appropriate solvent-free cleaning agents.
- To avoid tarnishing, brass surfaces (without surface protection) occasionally have to be treated with an appropriate care product.

Service and maintenance:

We recommend that such fittings be checked by specialists after every approx. 200,000 operations to conform their ongoing funktion integrity.

Lieferumfang:
Scope of delivery:

 4 mm

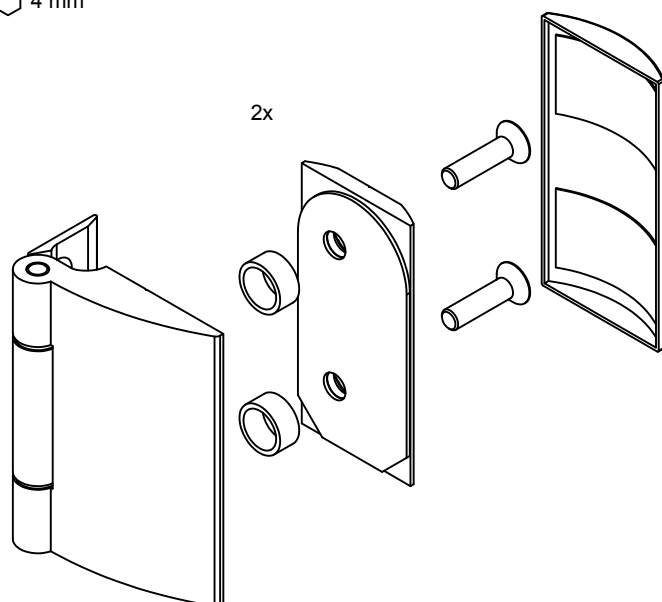

1. Montage des Beschlags ans Glas:
1. Installation of hinge onto glass:

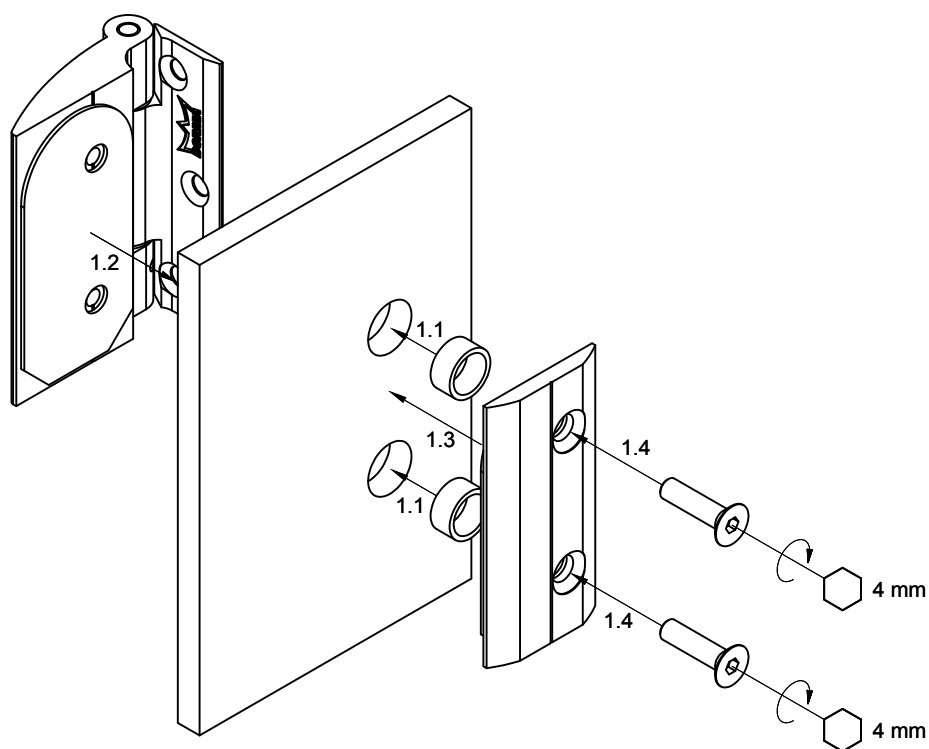

2. Bestimmung der Position der Beschläge:

2. Define the position of hinges:

2.1 Tür auf 7mm Klötze stellen und ausrichten

2.1 Place door at 7mm blocks and adjust

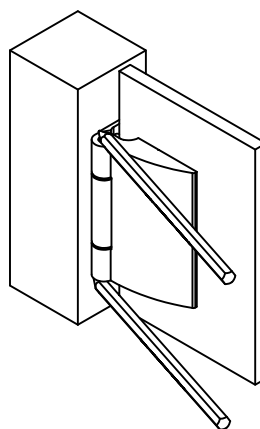
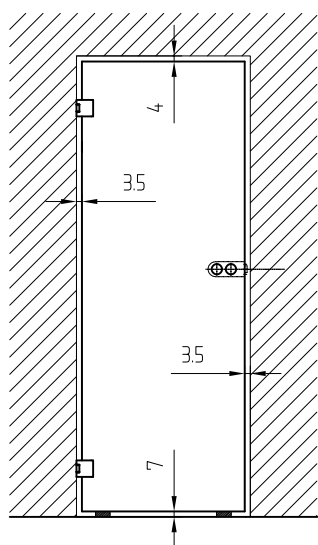

2.2 Position markieren
2.2 Mark the position

3. Demontieren der Beschläge:

3. Disassembling of hinges:

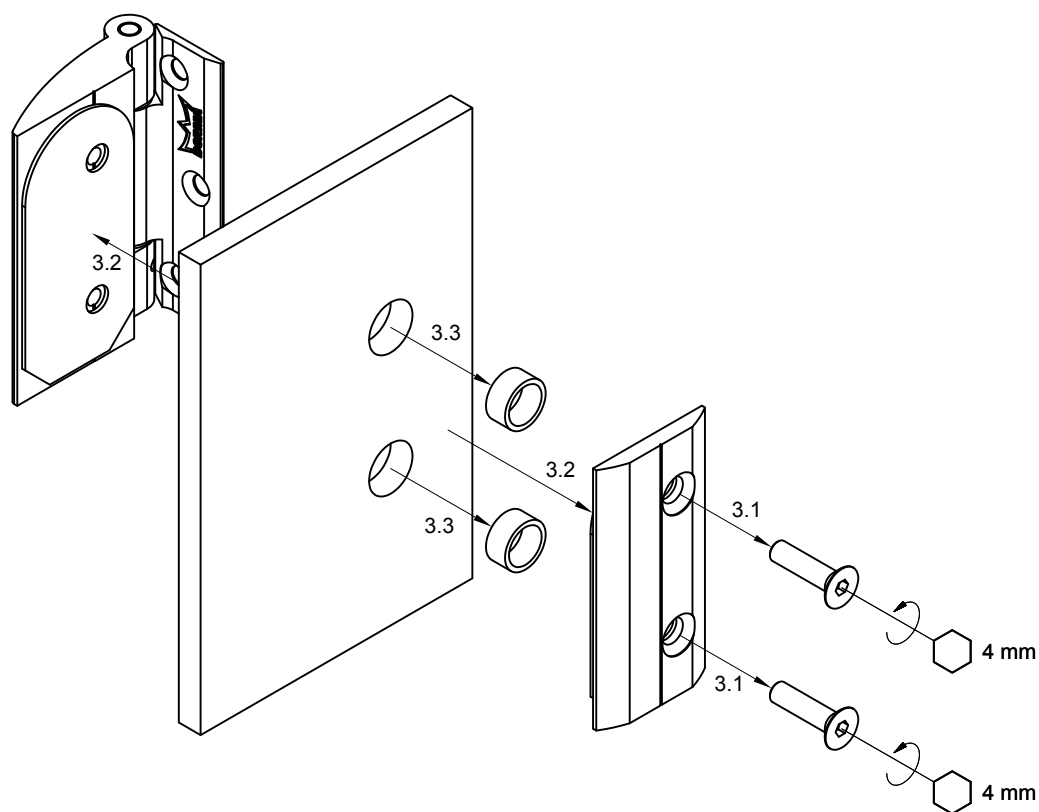

4. Befestigungs Bohrungen:
4. Attachment holes:

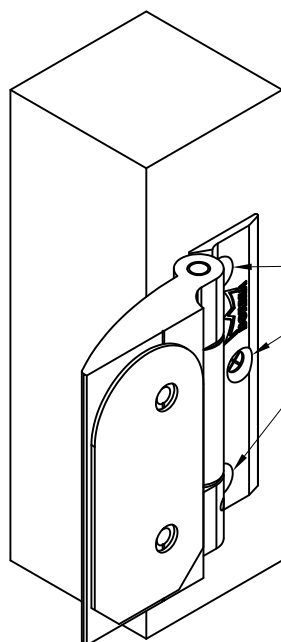

4.1 Alle Bohrungen markieren
4.1 Mark all holes

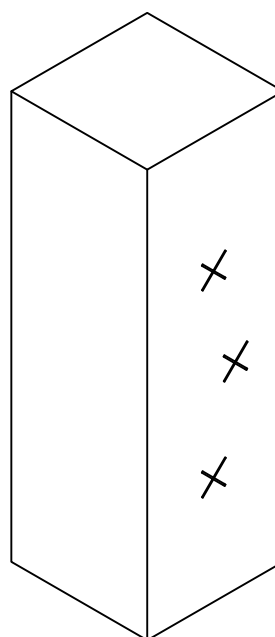

4.2 bohren
4.2 drill



abhängig von der
Befestigungsart



dependent to
attachment wise

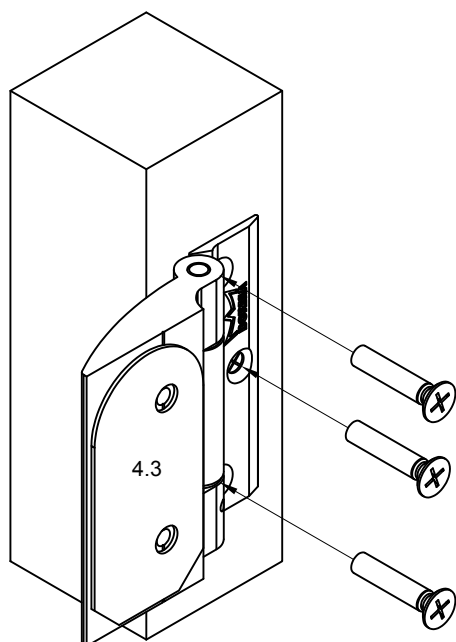

4.3



Befestigungsschrauben sind nicht im Lieferumfang enthalten!
Geeignete, auf den Untergrund abgestimmte Ankersysteme verwenden!



Attachment screws are not included in scope of delivery!
Please use suitable anchorsystems according to foundation!

5. Endmontage:
5. Final installation:

5.1 Tür auf 7mm Klötze stellen und ausrichten
 5.1 Place door at 7mm blocks and adjust

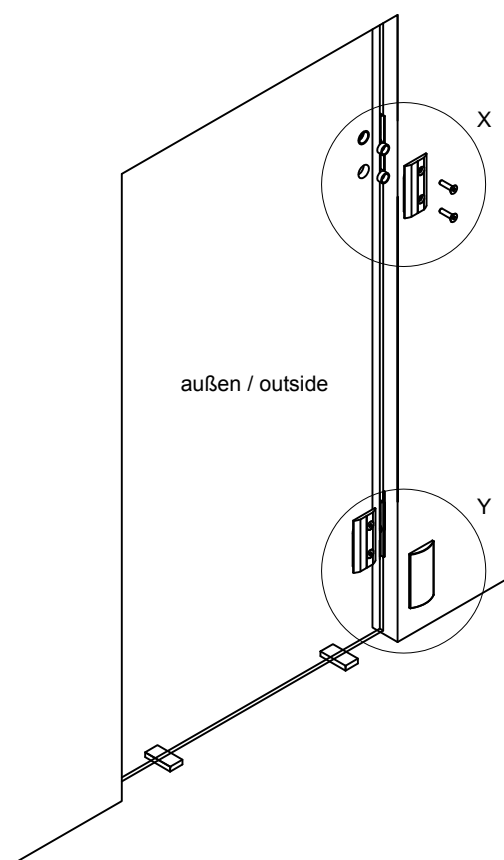
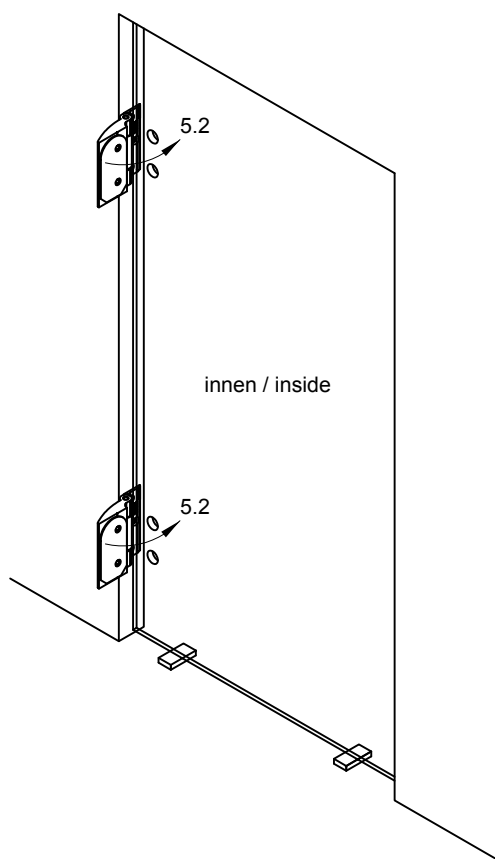
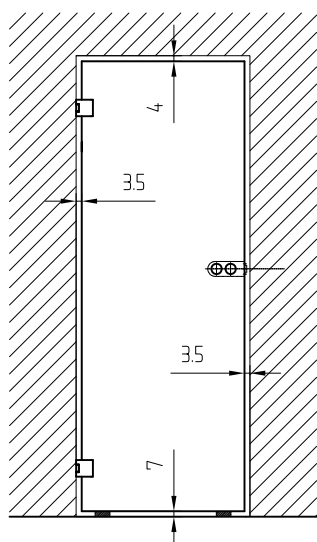

DETAIL X

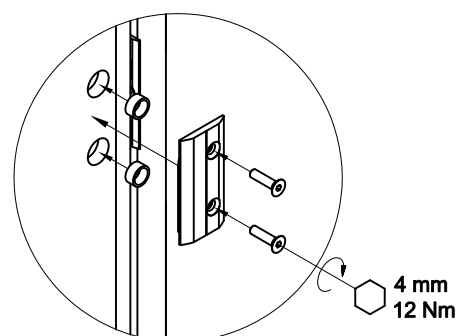

DETAIL Y

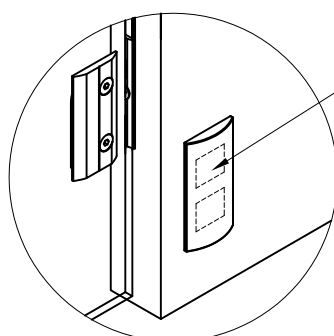

Doppelseitiges Klebeband:
 Folienstreifen abziehen
 Double-sided adhesive tape:
 pull off backing paper